

TERMS OF USE, WARRANTY AND LIABILITY WAIVER

TERMS OF USE

This Product is made available on the condition of your acceptance of the terms, conditions, and notices contained herein without modification. If you do not agree to these terms, return this Product within 10 days, including the packaging and all written materials, to MachineartMoto.

LIMITATION OF LIABILITY AND WARRANTY DISCLAIMERS

Machineart Inc., hereafter referred to as MachineartMoto, offers a money-back guarantee provided that the Product is returned, in unused condition with original receipt, within 30 days of purchase. Machineart Moto provides a 60 day warranty against defects in materials or craftsmanship. This warranty does not include damage due to normal wear and tear or misuse. Failure to comply with the included instructions for this Product will void the 60 day warranty. If you experience any problems with the Product within the warranty period please return the Product or contact us for prompt repair or replacement at our discretion.

Excepting the warranties stated in the preceding paragraph, Machineart Moto hereby disclaims all other warranties and conditions with regard to the Product including all implied warranties and conditions of merchantability and fitness for a particular purpose. There are no warranties which extend beyond the 60 day warranty as set forth above. Machineart Moto does not warrant against damages or defects arising out of use or installation of the Product.

To the extent allowed by law, Machineart Moto shall not be held liable for any direct, indirect, punitive, incidental, special or consequential damages arising out of, or connected with, the use or misuse of this Product. Buyer assumes all risks and liability arising from use of this Product. By accepting this product, the consumer agrees to arbitrate and litigate any controversy in the State of New Jersey, and under the laws of the State of New Jersey.

INSTALLATION INSTRUCTIONS

All MachineartMoto products should be installed by a qualified motorcycle technician. Installation instructions are provided for your information and convenience. Improper installation may cause injury or death. Machineart Moto is not responsible for any damages or loss of property which may result from installation, improper or otherwise, or use of the Product. No warranty of any kind, expressed or implied, is made regarding the safety of this Product. Failure to follow recommended installation and use instructions voids the warranty. By installing these products, user accepts all liabilities, terms and conditions outlined in the Liability & Warranty statement included herein. Installation instructions are written based upon our current state of knowledge. Information is provided without any guarantee as to its accuracy and is subject to revision.

IMPORTANT:

Before riding, sit on the machine and confirm that there is no interference with your ability to operate and ride the motorcycle safely. Check all controls, their cable paths, and part clearances to re-confirm that they are operating normally.

If you have any questions, please email us at sales@machineartmoto.com, or call (908) 652. 6779 9 am to 6 pm, Mon ~ Fri, Eastern time.

Machineart, Inc.
Frenchtown, NJ USA
www.machineartmoto.com

TOOLS REQUIRED:

May vary according to model

- T25 Torx Driver
- T30 Torx Driver
- T45 Torx Driver
- T55 Torx Driver
- 6MM Hex Driver

* BEFORE BEGINNING WORK,
READ THESE INSTRUCTIONS
FROM START TO FINISH.

* PLACE BIKE ON CENTER
STAND ON LEVEL GROUND.

* These instructions are written based upon our current state of knowledge. Information is subject to modification.

Due to motorcycle manufacturing tolerance variations from the factory or to owner made alterations, each installation is subject to modification to ensure proper fit.

GUARD KIT

Sets may come pre-assembled

- 1_INSERT - x2
- 2_GUARD - x2
- 3_GUARD SHIELDS - x2 (LEFT/RIGHT)
- 4_RETAINING WASHERS - x6
- 5_THUMBSCREWS - x6

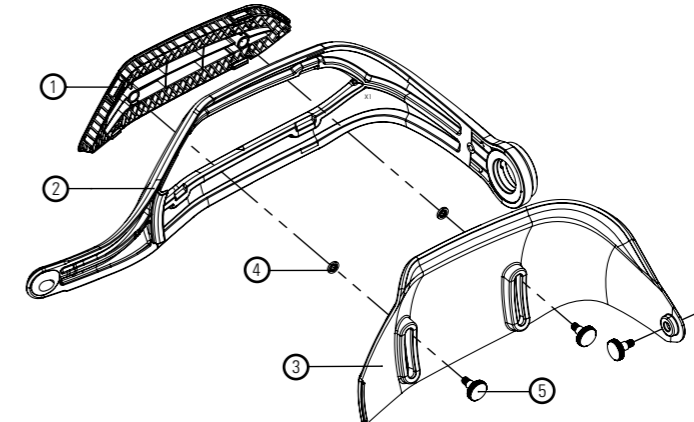

FITMENT KIT

NOTES: Contents are model specific.
Certain included parts may not be needed for your application.

Contents may be revised periodically according to changes made by Original Equipment Manufacturers.

KIT-1

FITS:
2013+ BMW R1200 GS/A LC

- MOUNT x2 Adjustable-Short
- BAR ADAPTER x2 Taper Bar
- MOUNT SCREW x4
- BAR CAP x2
- BAR END SCREW Reuse Stock Screw

FITS:
all years BMW F800GS/A
all years BMW F650/700GS

- MOUNT x2 Adjustable-Long
- BAR ADAPTER x2 F800 Taper Bar
- BAR ADAPTER x4 F650/700 7/8" Bar
- MOUNT SCREW x4
- BAR CAP x2
- M8 WASHER x2
- BAR END SCREW x2 M8 x 45

FITS:
Triumph Tiger 800/1200

- MOUNT x2 Adjustable-Long
- BAR ADAPTER x2 Taper Bar
- MOUNT SCREW x4
- BAR CAP x2
- BAR SPACER x2
- M6 WASHER x2
- BAR END SCREW x2 M6 x 40

KIT-2

FITS:
2005-2012 BMW R1200 GS
2013 BMW R1200 GSA

- MOUNT x2 Fixed
- BAR ADAPTER x2 Taper Bar
- MOUNT SCREW x4
- BAR END SCREW x2 M12 x 90
- BAR CAP Reuse Stock Cap

KIT-3

FITS:
Most ADV models: Honda AT,
KTM,

- MOUNT x2 Pivot Tip
- BAR ADAPTER x2 Taper Bar
- BAR ADAPTER x4 7/8" Bar
- MOUNT SCREW x4
- BAR CAP x2
- M8 WASHER x2
- BAR END SCREW x2 M8 x 60

IMPORTANT:

Installation requires technical experience. Machineart Moto products should be installed by a qualified motorcycle technician. Improper installation may cause injury or death.

We assume no liability for direct or consequential damage to the vehicle or personal injury caused by a fall, accident, or incorrect installation of our products.

START HERE

Follow assembly steps in order.

- * Place a soft cloth over your tank & fairing to protect them in case something is dropped.
 - * Remove any existing handguards, end weights & screws.
 - * At first, install screws loosely and apply LOCTITE 248 medium strength to screw threads. Tighten screws AFTER mounting all parts & making clearance adjustments.
- 1 Attach MOUNTS to the handlebar with MOUNT SCREWS & the correct BAR ADAPTERS for your model. Keep them semi-loose. You WILL need to adjust their position later.
 - 2 Position the GUARD against the handlebar END WEIGHT or SPACER, according to your model. Fasten the GUARD with the BAR END SCREW, WASHER, & BAR CAP. Use an M8 WASHER with an M8 SCREW, or an M6 WASHER with an M6 SCREW. Do not yet fully tighten.
 - 3 Fasten the narrow end of the GUARD to the MOUNT with the supplied MOUNT SCREW. Adjust the MOUNT position & angle to align with the mounting hole on the GUARD.
- * Check for adequate clearance with cables & wires. Adjust the GUARD angle so the clutch and brake lever ends align within the width of the GUARD lower bar.
 - * After both sides are installed, turn the handlebars full left & right to check for adequate clearance with the fairing, windscreen, & other area parts. Make adjustments & tighten all screws.

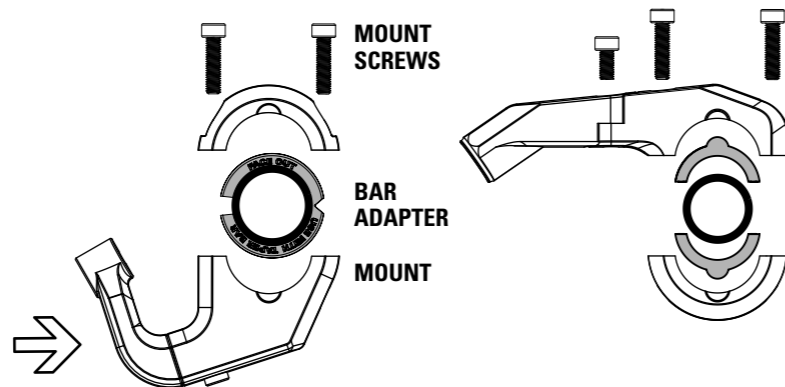

TAPER BAR ADAPTER:

1. Spread the Taper Bar Adapter over the handlebar with its flat side facing the end of the Bar.
2. Place the Mount & Clamp over the Taper Bar Adapter, hold them together & temporarily fasten with two Mount Screws.

7/8" BAR ADAPTER:

1. Position the Mount & Clamp on the handlebar & loosely fasten them with two Mount Screws.
2. Place two 7/8" Bar Adapters between the Mount & handlebar as shown. Engage the semi-circular tabs & tighten the Mount Screws some more. Do not fully tighten to allow final positioning with the Guard.

ADV GUARD ASSEMBLY

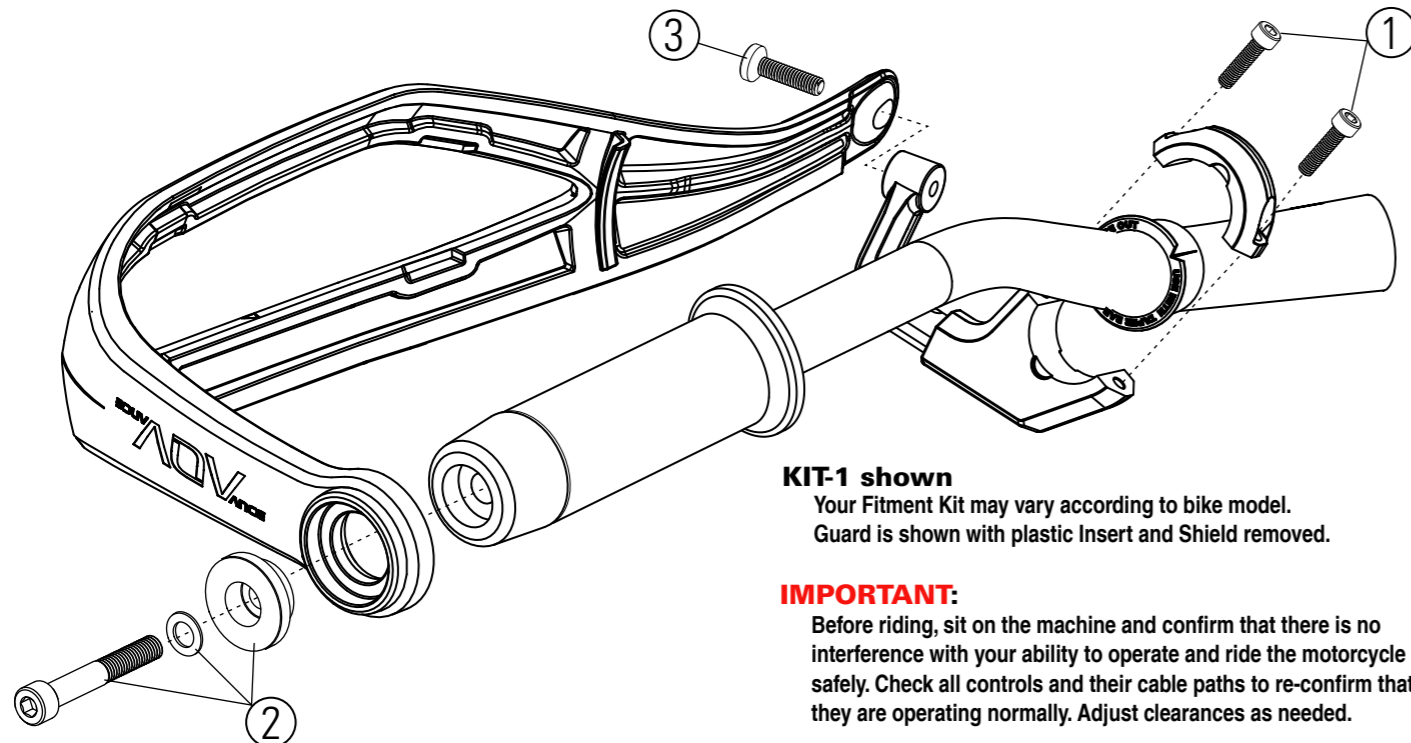

KIT-1 shown

Your Fitment Kit may vary according to bike model. Guard is shown with plastic Insert and Shield removed.

IMPORTANT:

Before riding, sit on the machine and confirm that there is no interference with your ability to operate and ride the motorcycle safely. Check all controls and their cable paths to re-confirm that they are operating normally. Adjust clearances as needed.

Check all bolted connections after initial ride. Tighten, if needed.

FIT KIT-1 Assembly

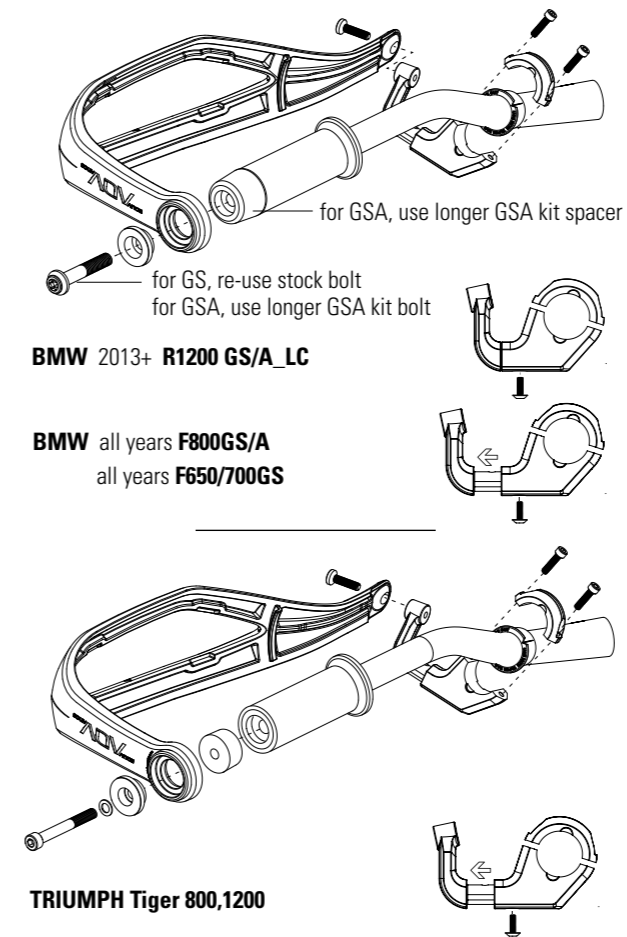

FIT KIT-2 Assembly

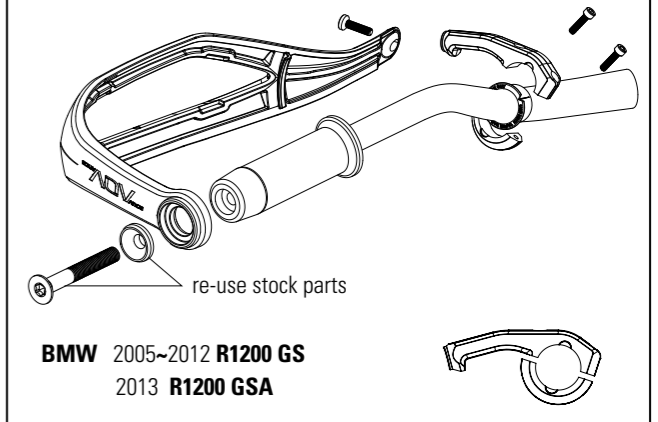

FIT KIT-3 Assembly

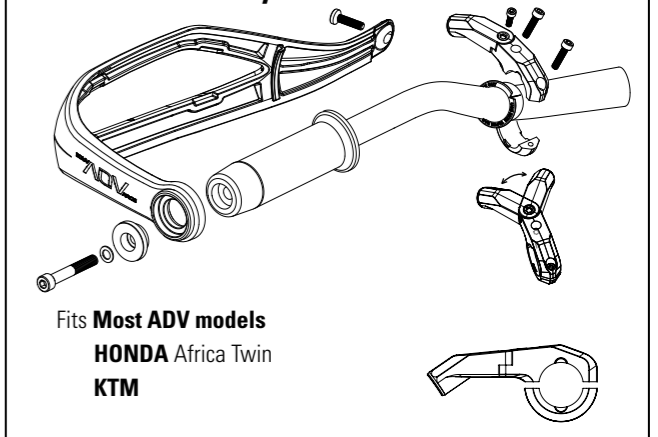

NOTE: Parts configuration is subject to revision

TO ADJUST SHIELD BIKE MUST BE STATIONARY!

1. Loosen all 3 Thumbscrews (do not remove from assembly).
2. Then, lift or lower Shield to the preferred position.
3. Tighten all Thumbscrews.

TO REMOVE SHIELD

1. Loosen all 3 Thumbscrews & disengage from the threads.
2. Remove Shield.
(Thumbscrews are retained with the Shield).

IMPORTANT:

NEVER attempt to ADJUST SHIELD WHILE RIDING! It can cause loss of control & result in serious injury or death.

TO REMOVE INSERT

1. Press 4 flex tabs with your thumbs & push the Insert out of the Guard.
2. To re-install, press Insert in from the front and snap into place.

IMPORTANT:

NEVER RIDE with ONLY the INSERT installed. INSERT and SHIELD must be fastened together.

